

# Encore Presentation System



## Complete Show Control

The Encore Presentation System is the most advanced video processing and presentation control system on the market today. The system provides source selection, advanced windowing features, seamless switching, video effects and integrated control for professional video presentations. Encore's modular, scaleable architecture allows the system to support a wide variety of show configurations. The system can efficiently support from 1-32 screens with any combination of independent display or seamless wide-screen display elements.

# Revolutionizing the event and entertainment industries

## UP TO 12 INDEPENDENT WINDOWS WITH Z-LEVEL CONTROL

Each window can be resized and positioned in real time.  
Flying window effects are controlled via keyframes.



## EXPANDABLE FROM 1 to 32 SCREENS

Encore supports any combination of single-screen, multi-screen or edge-blended widescreen applications.

**NATIVE HIGH RESOLUTION BACKGROUND**  
Background transition effects are independent of the windowing channels.



## SPECIAL EFFECTS

Seamless transitions, window border effects and advanced keying features are supported.

**MODULAR SYSTEM ARCHITECTURE**  
Encore can be expanded as your needs change and system configurations can be tailored to efficiently meet application requirements.



## TOTAL EVENT MANAGEMENT

Encore System Controllers provide easy to operate real-time control.

## System Overview

The Encore Presentation System is the most advanced video processing and presentation control system on the market today. The system provides source selection, advanced windowing features, seamless switching, video effects and integrated control for professional video presentations. Encore's modular, scaleable architecture allows the system to support a wide variety of show configurations. The system can efficiently support from 1-32 screens with any combination of independent display or seamless wide-screen display elements.

The Encore Video Processor incorporates universal inputs that accept both analog and digital video. Motion adaptive de-interlacing is provided for both standard and HD source video. Incoming videos are processed by Barco Folsom's proprietary Athena scaler. This scaler supports smooth real-time PIP movements and re-sizing based upon user specified Key Frames. The basic Encore configuration supports six independent PIP or Key images or three transitioning PIP images. Seamless transition effects, Z-order control, window borders, drop shadows and a variety of keying effects are fully supported. Two un-scaled background channels provide a high resolution backdrop that also supports seamless transition effects. Down Stream Key (DSK) effects are supported by a third un-scaled high-resolution input channel.

Two different Encore System Controllers models are offered to meet the varying demands of rental and staging professionals. The Encore Controller SC is designed for applications involving 24 input videos and can control shows with from 1-6 screens. The Encore Controller LC is designed for advanced applications involving up to 64 input videos and from 1-32 screens. Both controllers are capable of controlling external routers for external source selection and Encore Video Processor units to provide high-performance real-time video effects. The controllers can also be used with Barco's Events Manager software to synchronize operation with external devices and to run pre-programmed show sequences. The controllers use an embedded Real-Time Operating System (RTOS) to provide high reliability, rapid power-up and true real-time performance for critical video processing sequences.

## Features

·Supports up to 12 Independent windows or 6 windows with seamless transitions

·(2) Native High Resolution Background channels provide background video with seamless transition effects

### ·Special Effects

- A full range of transition effects (dissolve, wipe, etc.)
- Smooth PIP Move & Sizing controlled via Key Frames
- Adjustable PIP Aspect Ratio
- PIP Borders, including Drop Shadows and Soft Edge
- PIP Clone (Mirror and Offset)

### ·Keying

- Luminance Key
- Split Key (Key Alpha and Fill)
- Reverse Key (Key on Background)
- Color Key (Graphics)
- Alpha Mixing

·(1) Native High Resolution Down Stream Key channel independent of PIP/KEY processing channels

### ·Video Processing

- 10-bit Processing
- 1:1 Pixel Sampling
- Motion Adaptive De-interlacing (SD & HD)
- 3:2 and 2:2 Pull Down Detect
- Image Cropping
- Aspect Ratio Correction

·Athena Proprietary High-Performance Scaling

·Low Video Delay - Less than 3 Input Fields

·Z-order Control (Priority layers) for overlapping PIP or Key Images

·Each Mixer Layer is dynamically re-assignable as a mixing (transitioning) PIP, or as two individual (SPLIT) non-transitioning PIP or Key Images.

·Still Frame : Frame Grab of Background and Down Stream Key sources

·Complete Look-ahead Preview

·On-Screen Display (Preview monitor) of Layer Information and Status

·Supports Blended Widescreen Projection

·Output Synchronization: Free-Run or Vertically Locked to NTSC/PAL Blackburst

### ·Edge Blending

- 10-bit Processing
- Variable Overlap
- Supports standard and pre-overlapped Background sources
- Edge Blending (Feathering)

## The Encore Video Processor

The Encore Video Processor is packaged as a 3RU rack-mount unit. Encore Video Processors are sold with one, two or three Mixer/Effect (M/E) boards to meet different application requirements. Models ordered with one or two M/E boards can be easily upgraded by addition of additional M/E boards.

Each M/E board provides two independent Athena scaler channels with universal inputs that handle both analog and digital video sources. The unit accepts standard component and composite analog video formats (NTSC, PAL, SECAM), SDI video, computer resolutions up to 1600x1200, analog HD formats including 720p, 1080i, 1080p, HD-SDI Video, 2048x1080p Digital Cinema video, and Plasma display resolutions. The Athena scaler features 1:1 pixel sampling, motion adaptive de-interlacing for both standard and high definition sources, 3:2 and 2:2 pull down detection, low video delay, aspect ratio correction, image cropping and real-time window re-sizing and positioning. Seamless transition effects, window borders, drop shadows and a variety of keying effects are fully supported.

The baseline Encore Video Processor configuration is a unit with three M/E boards. A unit configured in this manner can scale six input sources to generate PIP and/or Key images. PIP and Key images can be sized and positioned at any location on the screen in real-time. Z-order control is used to assign overlay priorities to each PIP or Key image. PIP images can be linked in pairs to support PIP transition effects or displayed independently and transitioned onto the background image. Key images are used to provide a variety of key effects such as superimposing titles on the image or creating special mask effects. Each Encore Video Processor also supports two native resolution background channels to provide a high resolution backdrop for the PIP images. Seamless transitions are also supported on the background image. In addition to six scaled inputs and a transitioning background, the unit supports a high resolution Down Stream Key (DSK) input.

Each Encore Video Processor incorporates one Output Board. This board provides all output interface functions as well as blending and data-doubling functions required to support widescreen applications. Output resolutions supported include computer resolutions up to 1600x1200, analog HDTV resolutions including 720p, 1080i, 1080p, HD-SDI Video, 2048x1080p Digital Cinema video, and Plasma display resolutions. Output synchronization is supported to lock the output frame rate to an externally applied NTSC/PAL black burst signal.



Encore Video Processor Rear Panel

## How Layers Work

Within the Encore system, a Layer is defined to be an image display element, such as a Background, PIP (Picture-in-Picture) Image or Key Image.

A typical application is illustrated below.

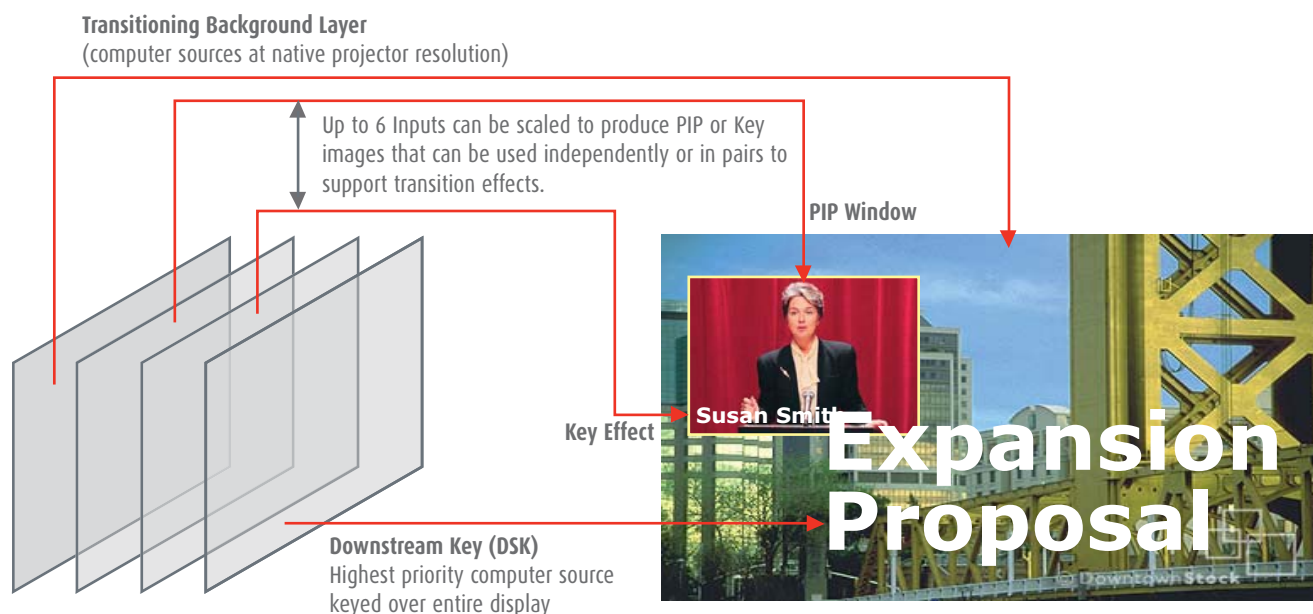

# Creating effects with Encore

The possibilities are virtually endless. Sources can be combined to produce stunning visual effects.

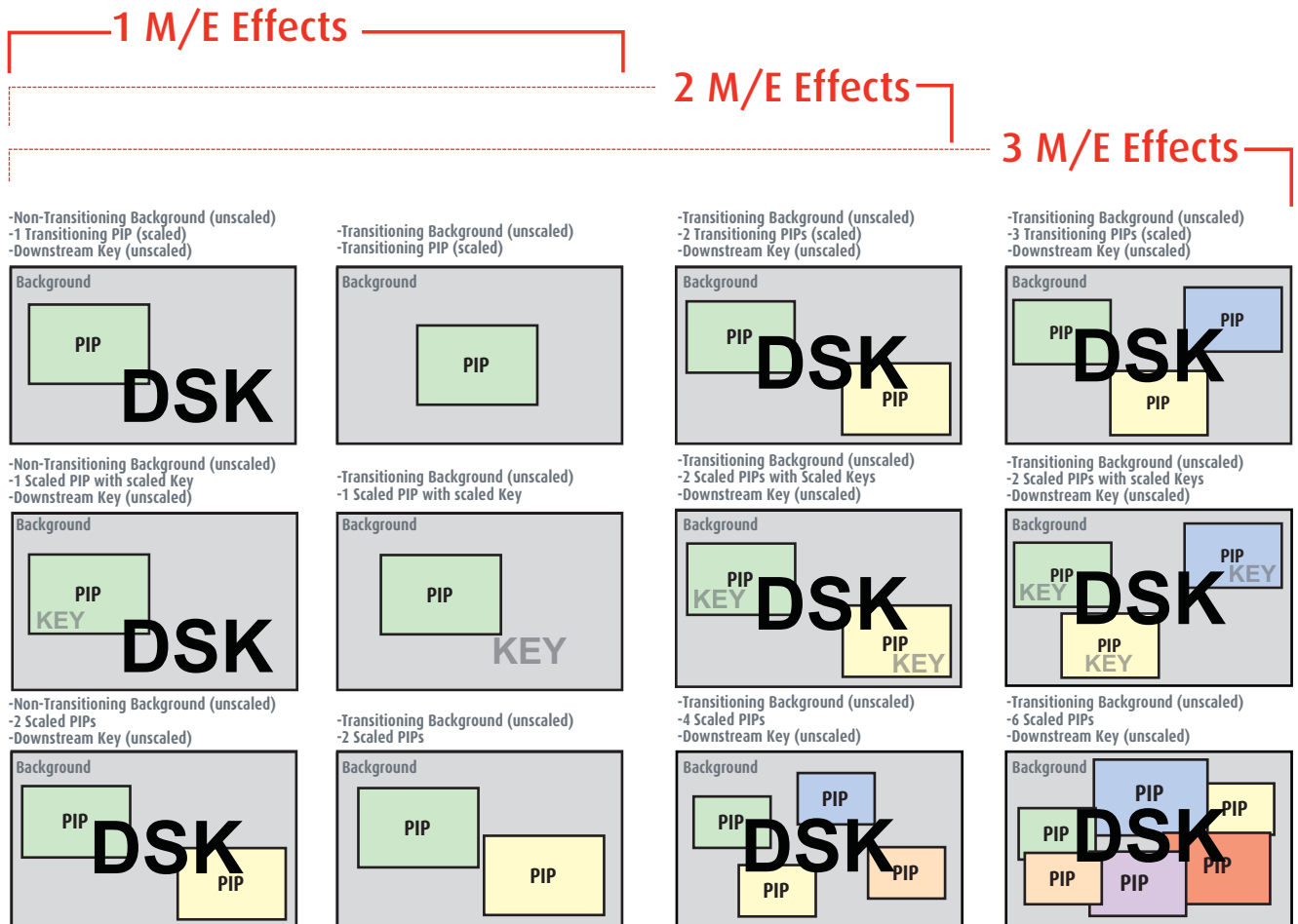
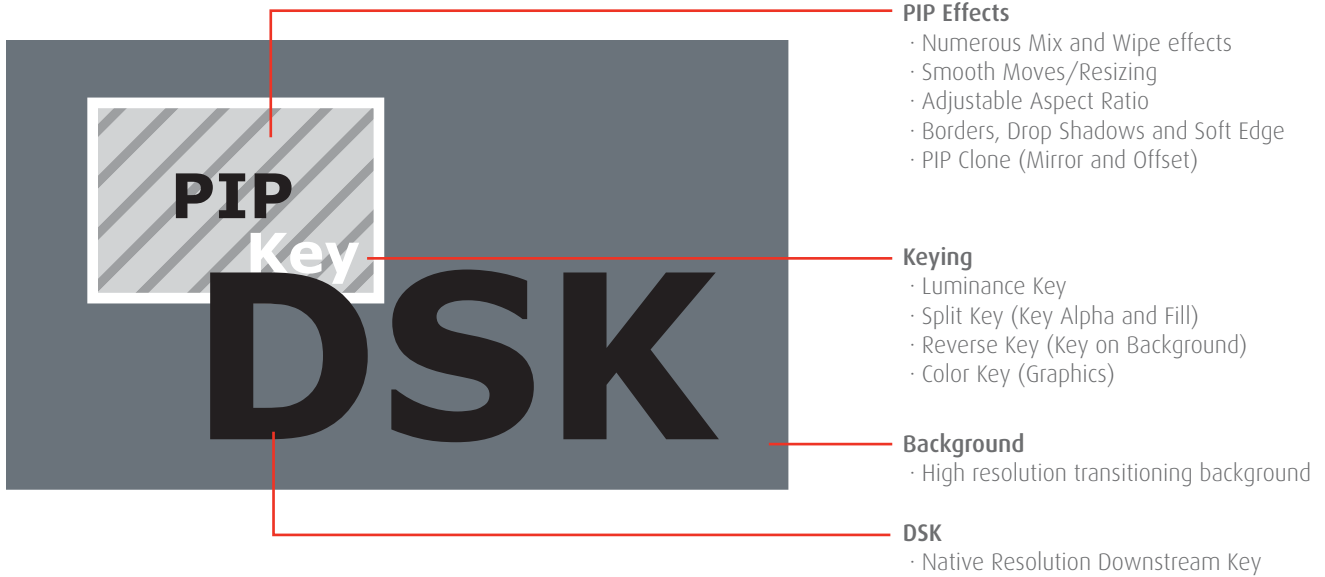

# Total Event Control

The Encore System Controllers support events by allowing integrated control of multiple Encore Video Processors in addition to matrix switches.

## Encore Controller LC

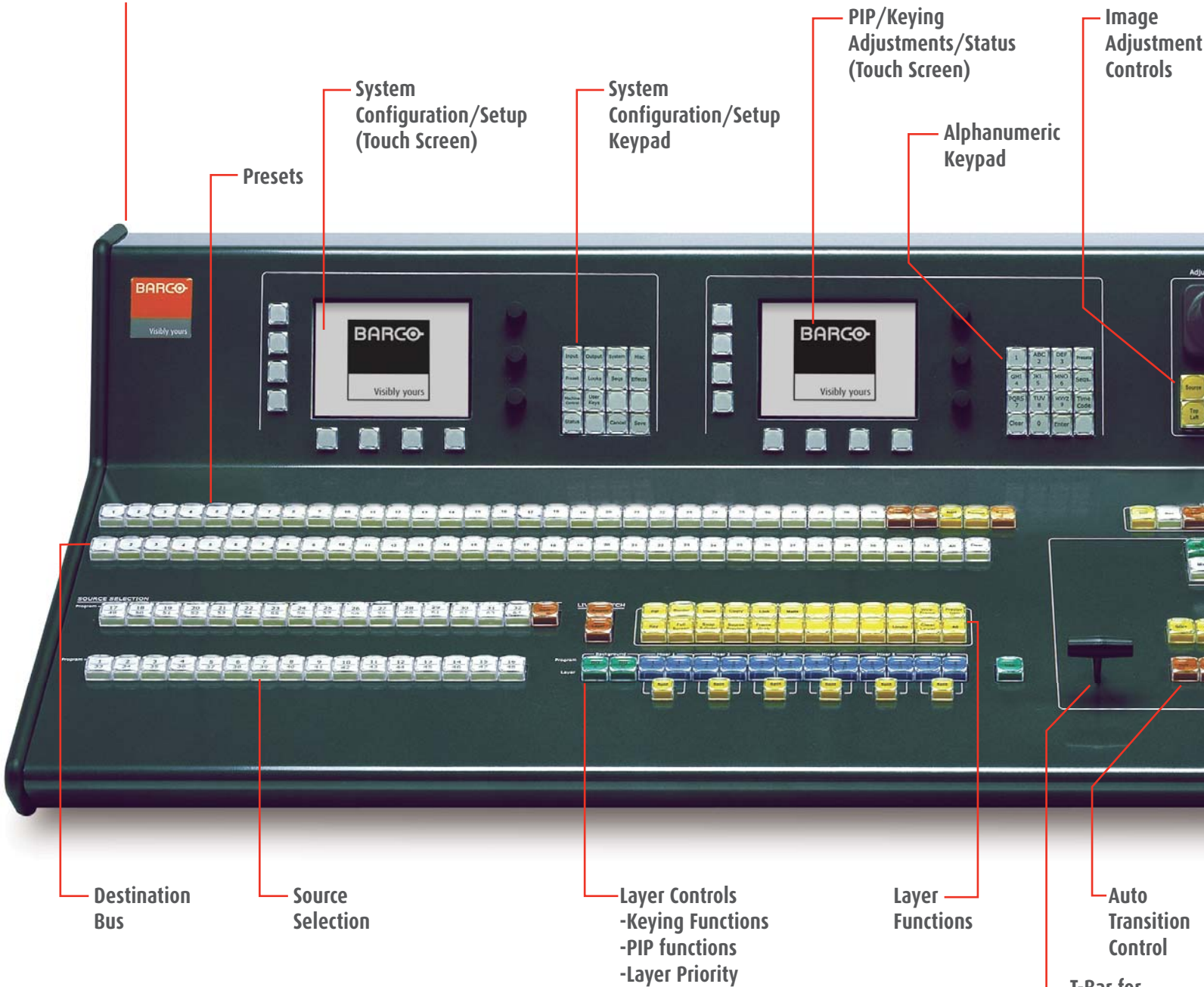

Each mixer can be used in normal or split mode



Full Machine Control



Joystick for intuitive image adjustments

## Controller Features

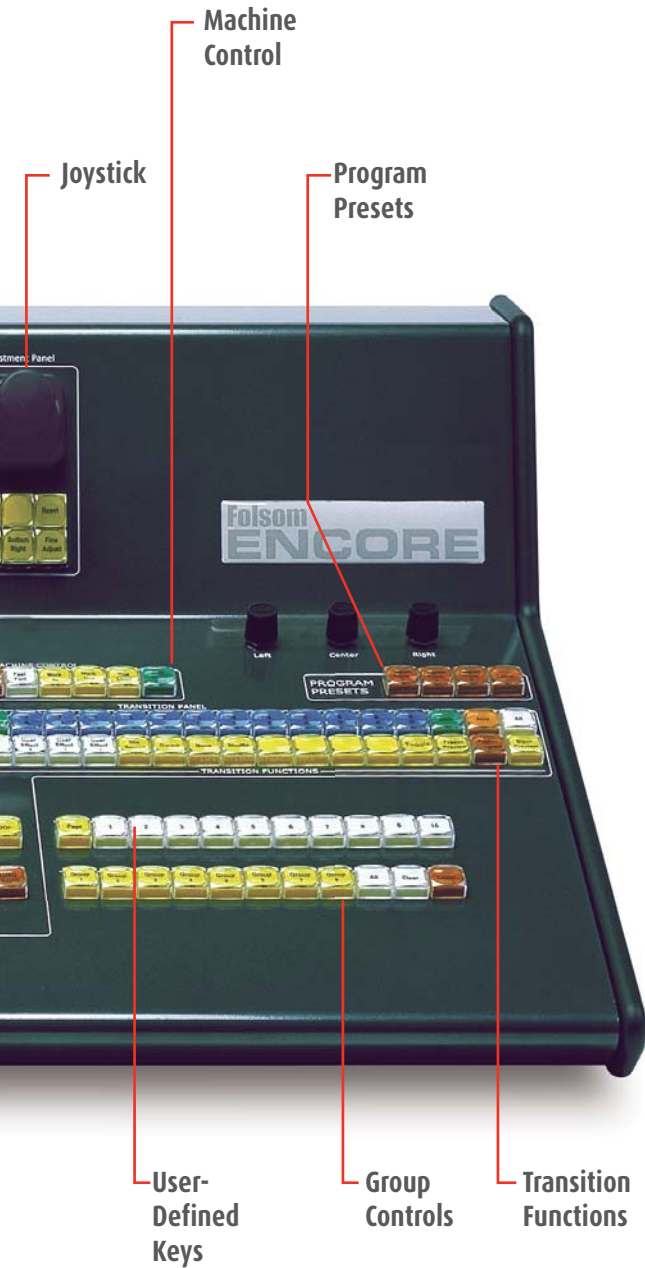

	Small Controller	Large Controller
Encore Processors supported	6	32
Widescreen support	Yes	Yes
External Router Control	Yes	Yes
Inputs supported	24	64
Destinations supported	6	32
Available Presets	64	900
Layers supported	1 DSK 6 Scaled Inputs (PIP or Key) 1 Transitioning background	1 DSK 12 Scaled Inputs (PIP or Key) 1 Transitioning background
User-selectable Transition Functions	Yes	Yes
Available Destinations	4	8
Available User-defineable Keys	None	100
Joystick & T-Bar	Yes	Yes
Machine control	No	Yes
320 x 240 graphic displays	1	2
Light sticks	2	3
PS/2 Keyboard support	Yes	Yes
Communication	Ethernet, RS-232, USB	Ethernet, RS-232, USB
Program Sequencing	Yes	Yes
Field Upgradable	Yes	Yes
Ethernet Control Interfaces	Yes	Yes
Tally support	8	8



Encore Controller SC

# Encore Configurations

## Single Screen Application

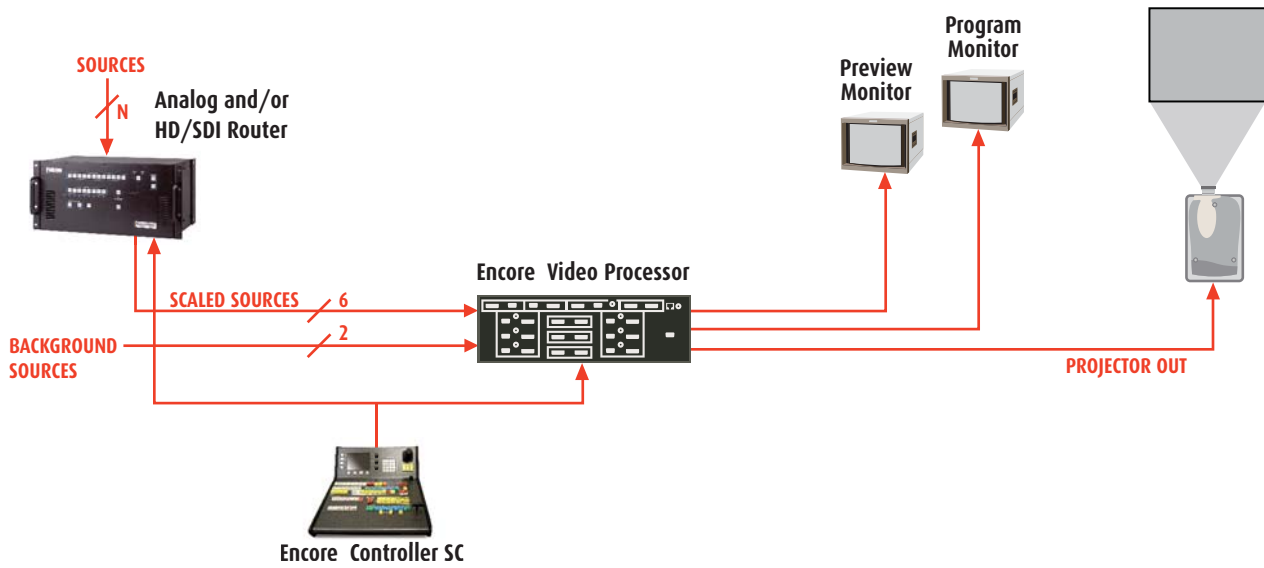

---

## 3 Screen Application

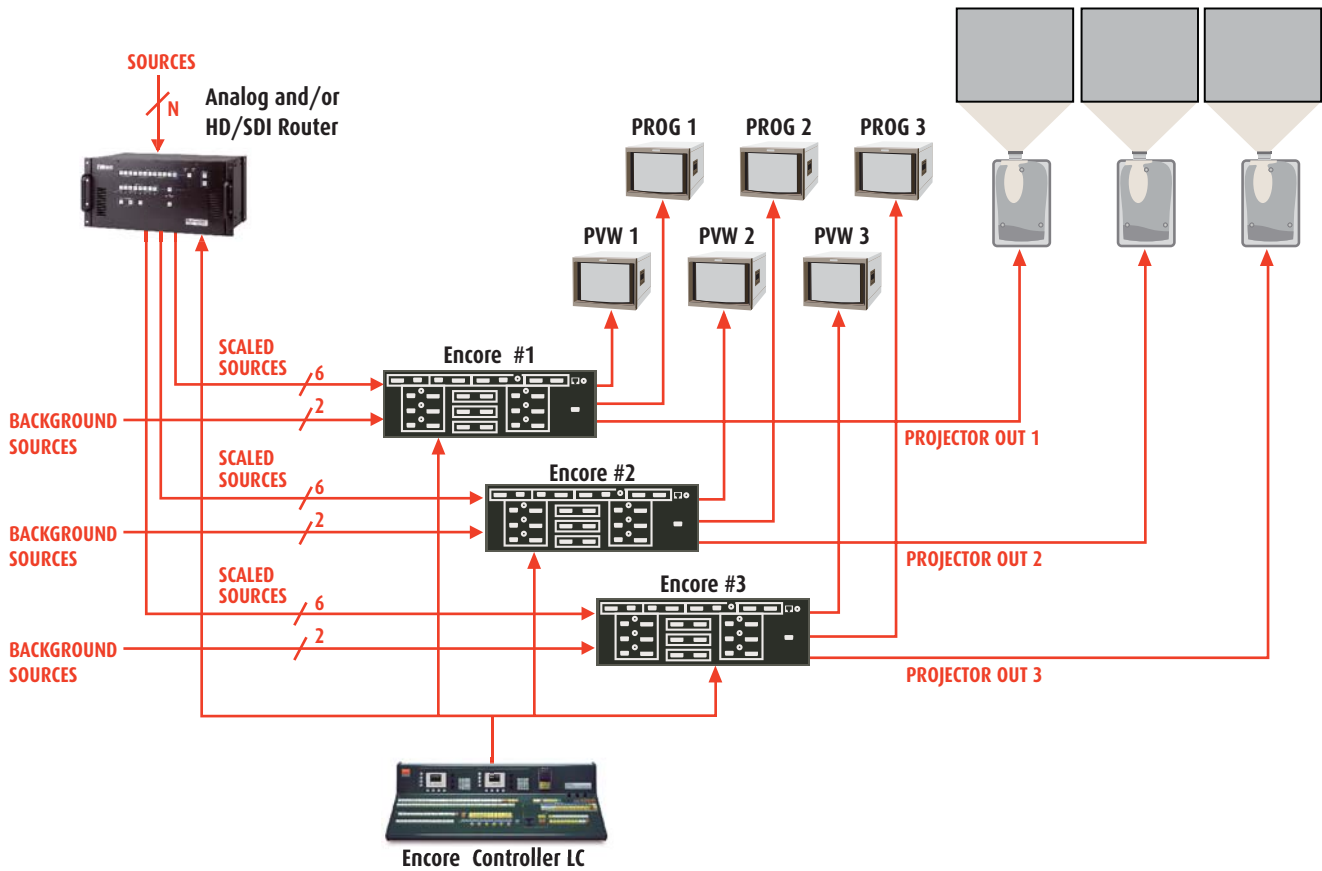

## Wide-Screen Application

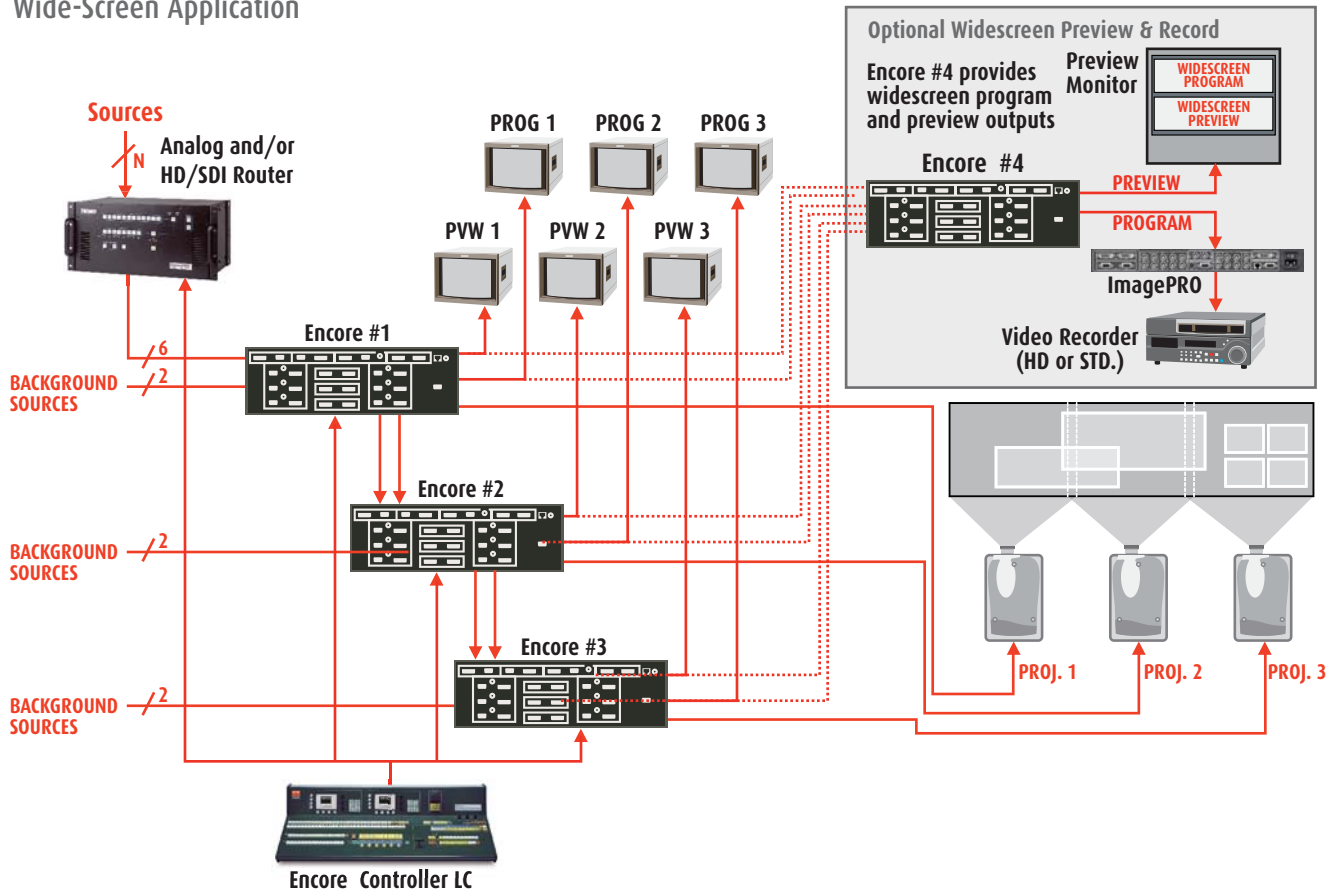

## Single Screen Expansion to 12 Windows

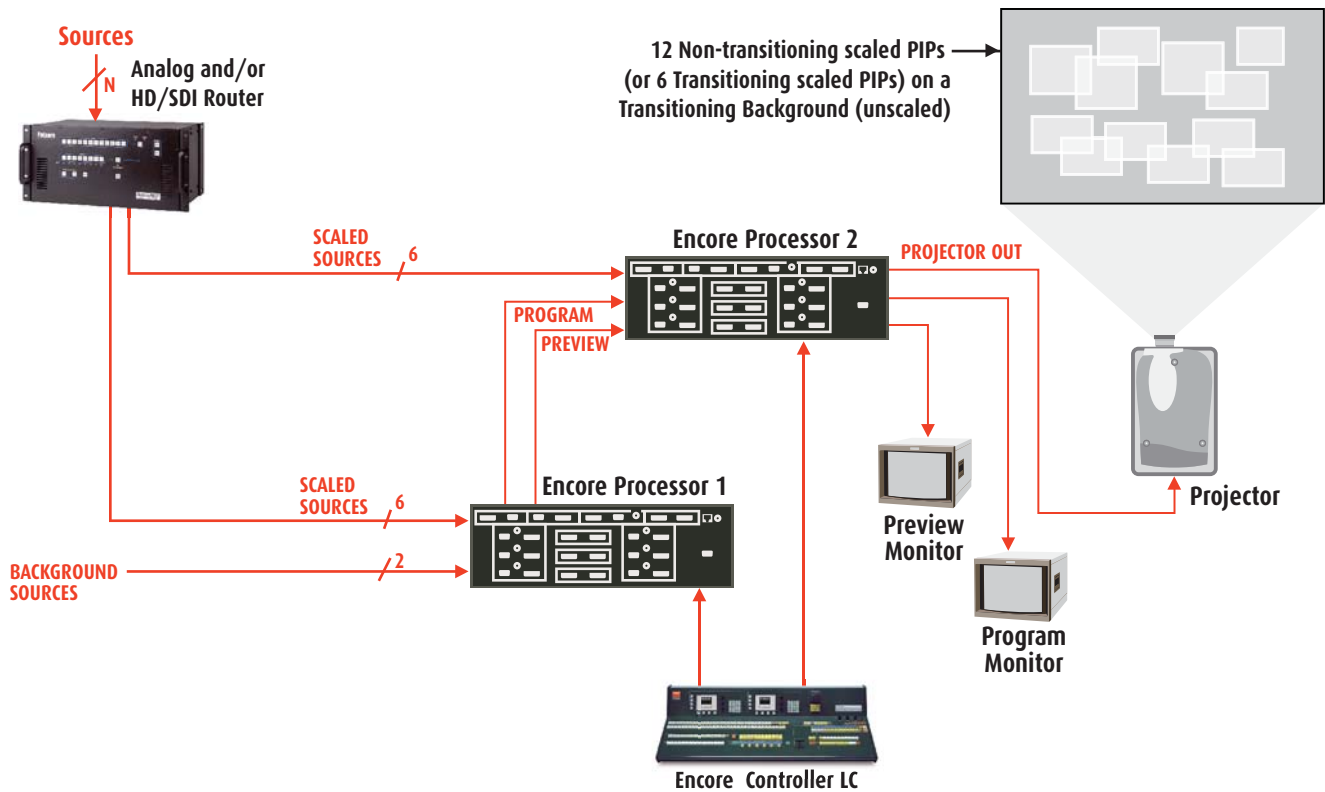

## Integration with Signal Routers

The use of high quality routers is an integral part of the Encore system. Barco is pleased to announce a complete line of routers for use with the Encore system. The line consists of a variety of both analog and digital routers including SDI and HD/SDI units. All of our routers are designed and tested to ensure quality, reliability and ease of use.

The Encore system is also compatible with other manufacturers' routers.



MatrixPRO™ Matrix Switcher

## Event Management

The Encore Presentation System has been designed to be compatible with Barco Events Manager software. The Events Manager software complements the real-time control features of the Encore system by supporting enhanced external device control capabilities and sophisticated pre-programmed control sequences.

The Events Manager treats the Encore system as a peripheral device and sends commands to the controller to execute time-line programmed sequences of effects. This allows Encore system functions to be fully integrated with other show effects. In addition, the range of external devices that can be controlled is greatly increased, permitting a user to automate an entire show.

The Events Manager software also supports the management of digital media sources.

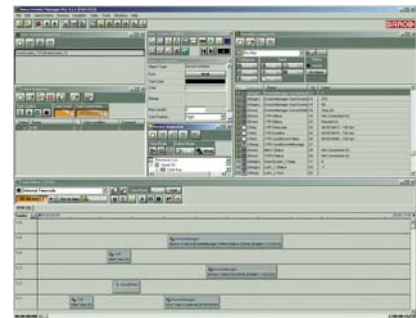

Event Manager Software

## Show Planning Tools

The Encore Show Planner software package is an interactive PC-based tool that is used to plan Encore shows. The tool allows the basic design of a show to be developed on a laptop - anywhere you can operate a computer - without any specialized hardware.

Show configuration parameters (screen size, resolution, projector placement, blend region definition, etc.) are first determined. After the basic configuration parameters for the show have been established, source selection and sequences of video effects can be programmed to create a simulated show. The simulated show can be previewed and edited as required. When the user is satisfied with the characteristics of the show, configuration parameters and presets can be stored in a Show Configuration File.

Upon arrival at the show site, the Show Configuration File can be downloaded into the Encore system, tested and edited with actual source content. After testing is complete, the information stored in the Encore Controller can be saved as a final Show Configuration File. This file can then be reused to set up future shows or edited to produce new show content without starting from scratch.

## Encore Video Processor Specifications

Inputs		
Mixer/Effects Channels (2 per m/e board)	Analog Inputs	RGBHV/RGBS/RGSB computer video, YPbPr video (SD or HD), S-video, or Composite video on 15-pin HD connector
	SD and HDSDI Input	per SMPTE 259M-C (NTSC/PAL resolution) SMPTE 292M (HDTV) on BNC connector
	DVI Input	per DDWG 1.0 on DVI-I connector
	Input Resolutions	<ul style="list-style-type: none"> <li>· NTSC/PAL</li> <li>· Computer Resolutions VGA (640 x 480) through UXGA (1600 x 1200)</li> <li>· HDTV Resolutions up to 1920 x 1080 (720p, 1080i, 1080p)</li> <li>· 2048 x 1080p (Digital Cinema format)</li> <li>· Plasma Display Resolutions</li> </ul>
Native Resolution Background Channels (2 per m/e board)	Analog Inputs	RGBHV computer video on DVI-I connector
	DVI Input	per DDWG 1.0 on DVI-I connector
	Input Resolutions	<ul style="list-style-type: none"> <li>· Computer Resolutions: SVGA (800 x 600) through UXGA (1600 x 1200)</li> <li>· HDTV Resolutions (720p, 1080p)</li> <li>· 2048 x 1080p (Digital Cinema format)</li> <li>· Plasma Display Resolutions</li> </ul>
Downstream Key Input (1 per Encore Video Processor)	Analog Inputs	RGBHV computer video on DVI-I connector
	DVI Input	per DDWG 1.0 on DVI-I connector
	Input Resolutions	<ul style="list-style-type: none"> <li>· Computer Resolutions: SVGA (800 x 600) through UXGA (1600 x 1200)</li> <li>· HDTV Resolutions (720p, 1080p)</li> <li>· 2048 x 1080p (Digital Cinema format)</li> <li>· Plasma Display Resolutions</li> </ul>
Frame Lock Input		NTSC/PAL black burst reference on BNC Connector
Outputs		
Preview Output	Analog Outputs	RGBHV/RGBS/RGSB, YPbPr video (SD or HD), on 15-pin HD connectors
	DVI Output	per DDWG 1.0 on DVI-I connector
Program Output 1	Analog Outputs	RGBHV/RGBS/RGSB, YPbPr video (SD or HD), on 15-pin HD connectors
	DVI Output	per DDWG 1.0 on DVI-I connector
	Optional HDSDI Output	per SMPTE 259M-C (NTSC/PAL resolution) SMPTE 292M (HDTV) on BNC connector (Program Out)
Program Output 2	Function	This output can be programmed to serve as a second buffered program output or a monitoring program output
	Analog Outputs	RGBHV/RGBS/RGSB, YPbPr video (SD or HD), on 15-pin HD connectors
	DVI Output	per DDWG 1.0 on DVI-I connector
	Optional HDSDI Output	per SMPTE 259M-C (NTSC/PAL resolution) SMPTE 292M (HDTV) on BNC connector (Program Out)
Ethernet		RS-232
Output Resolutions		<ul style="list-style-type: none"> <li>· Computer Resolutions VGA (640 x 480) through UXGA (1600 x 1200)</li> <li>· HDTV Resolutions up to 1920 x 1080 (720p, 1080i, 1080p)</li> <li>· 2048 x 1080 (Digital Cinema format)</li> <li>· Plasma Display Resolutions</li> </ul>
Mechanical		3 RU Rackmount Chassis
Power		120-240 VAC - 50/60 Hz., Autoselecting 1.0A maximum

**Folsom**

[www.folsom.com](http://www.folsom.com)  
[www.events.barco.com](http://www.events.barco.com)

**Barco Events USA**  
11101 Trade Center Drive Rancho Cordova, CA 95670  
Tel. 916 859 2500 Fax 916 859 2515

